

SPECIFICATION FOR TFT MODULE

MODULE NO: YB-TG800480S37A-N-A0

Doc.Version:00

Customer Approval:

<input type="checkbox"/> Accept	<input type="checkbox"/> Reject
---------------------------------	---------------------------------

YEEBO	NAME	SIGNATURE	DATE
Prepare	Electronic Engineer	温育华	2023-9-21
Check	Mechanical Engineer		
Verify			
Approval			

■ APPROVAL FOR SPECIFICATIONS ONLY

□ APPROVAL FOR SPECIFICATIONS AND SAMPLE

WIMRD005-02-D

1. Revision History

Sample Version	DOC. Version	DATE	DESCRIPTION		CHANGED BY
A0	00	2023-09-21	Spec Only	First issue	Couver / Z.J.W

2. Table of Contents:

NO	CONTENTS	PAGE
1	Revision History	1
2	Table of Contents	2
3	Module Numbering System	3
4	General Specification	4
5	LCM drawing	5
6	Electrical Characteristics	6
7	Optical Characteristics	11
8	Interface Pin Assignment	13
9	Block Diagram	14
10	Backlight	15
11	Standard Specification for Reliability	16
12	Specification of Quality Assurance	18
13	Handling Precaution	24
14	Warranty	27
15	Guarantee	28

3. Module Numbering System:

(Example)

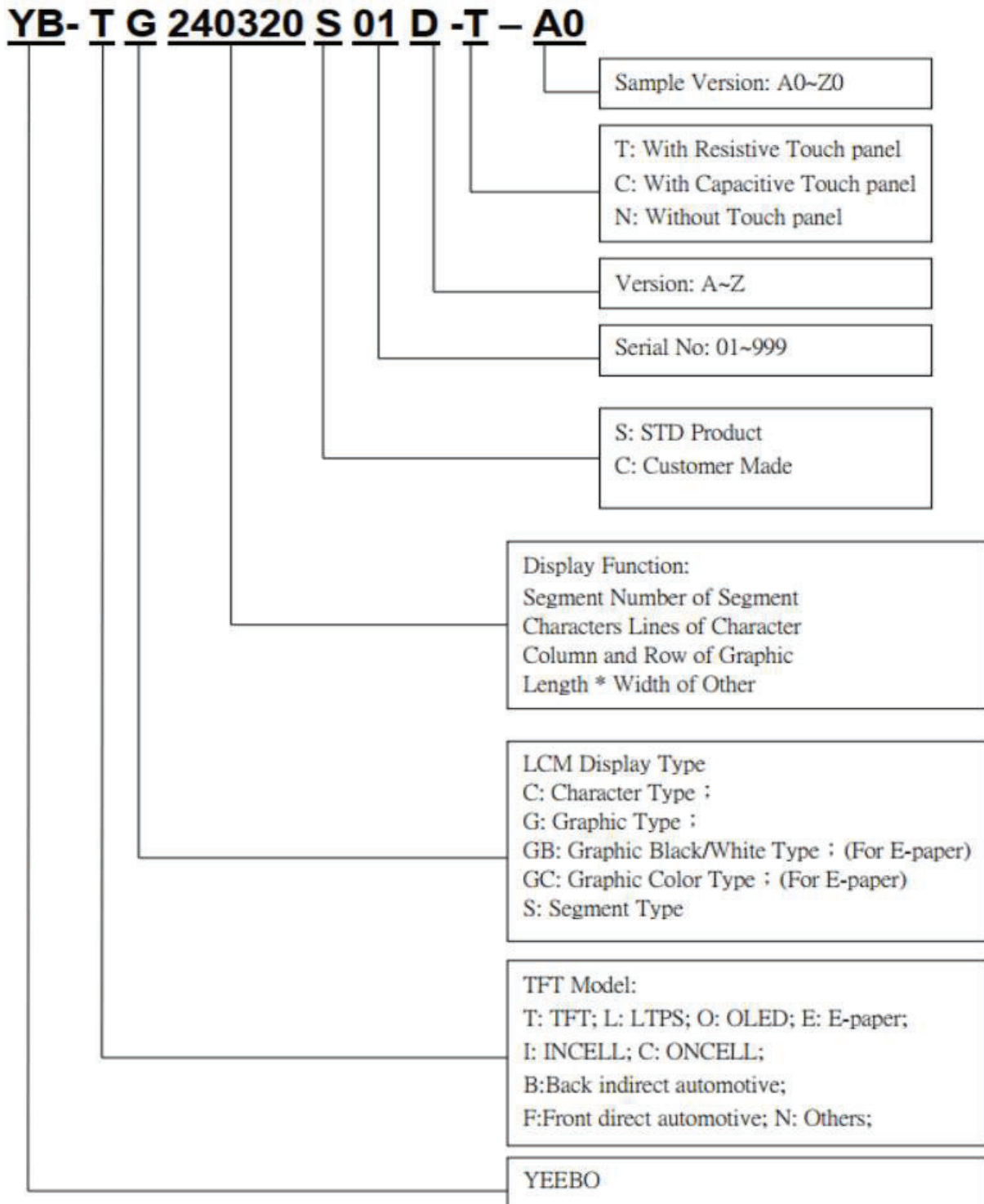

4. General Specification:

ITEM	CONTENTS
Module Size	166.6 (W) * 105.8 (H) * 18.4(T) mm
Module Size(With FPC)	166.6 (W) * 105.8 (H) * 18.4(T) mm
Display Size (Diagonal)	7.0 inch
Display Format	800(RGB)* 480 Pixels
Active Area	152.4 (W) * 91.44 (H) mm
Dots Pitch	0.1905 * 0.1905 mm
LCD Type	TFT (16.7M)/ Transmissive / Normal Black
View Angle	Free
Weight	TBD

5. LCM drawing:

Rev. #1	Count drawing & Spec, revision record during discussion with customer	Date
	Revision content description	
	FIRST ISSUE	2023-05-15

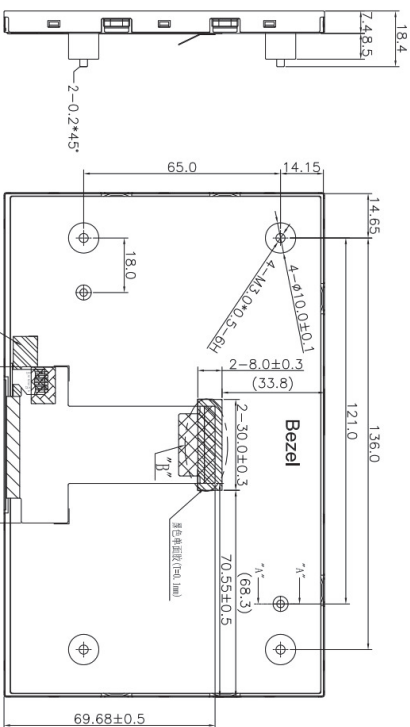
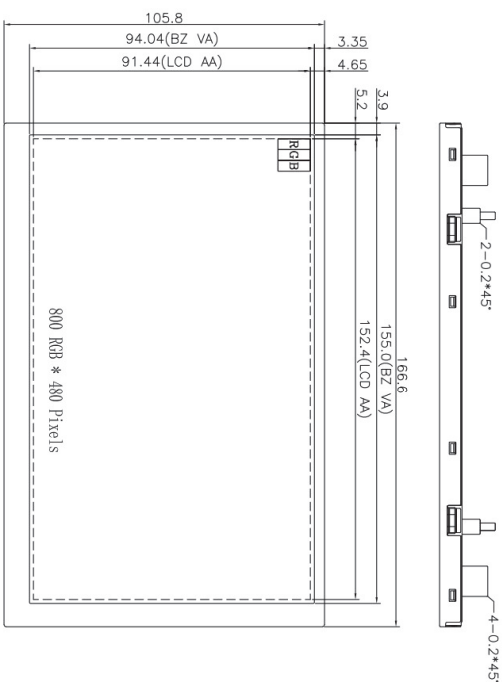

Specification:

1. Display mode: 7.0" TFT / Normal Black / Transmissive
2. Display Color: 16.7M
3. Viewing direction : Free
4. Driver IC:
5. Operating temperature: -30°C to +85°C
6. Backlight: 21chips White LED (车载灯)
7. Unspecified tolerance: ±0.30mm.
8. ROHS compliant
9. Luminous Intensity for LCM: 800cd/m2(min), 1000cd/m2(typ)
10. Product structure: TFT

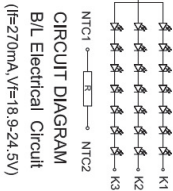
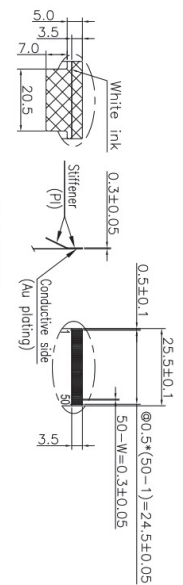
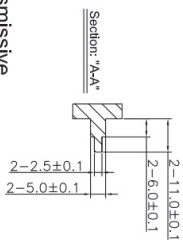

YEEBO		MOD. Name	DESIGNED	CHECKED	VERIFIED	APPROVED	FILE NAME
YEEBO		YB-TG800480S37A-N-A	王珺琳				Count Dwg.
UNIT	SIZE	SCALE	DESIGNED	CHECKED	VERIFIED	APPROVED	FILE NAME
mm	A4	N-T-S	2023-05-15				Count Dwg.

1	LED+	FPC PIN OUT
2	LED+	
3	LED-	
4	LED-	
5	GND	
6	VCOM	
7	DVDD	
8	MODE	
9	DE	
10	VSYSNC	
11	HSYNC	
12	B7	
13	B6	
14	B5	
15	B4	
16	B3	
17	B2	
18	B1	
19	B0	
20	G7	
21	G6	
22	G5	
23	G4	
24	G3	
25	G2	
26	G1	
27	G0	
28	R7	
29	R6	
30	R5	
31	R4	
32	R3	
33	R2	
34	R1	
35	R0	
36	GND	
37	DCLK	
38	GND	
39	LCD_LR	
40	LCD_UD	
41	VGH	
42	VGL	
43	AVDD	
44	RST_LCD_N	
45	NC	
46	VCOM	
47	LCD_DITHB	
48	GND	
49	NC	
50	NC	

6. Electrical Characteristics

6-1 Absolute Maximum Ratings

Item	Symbol	Min.	Type	Max.	Unit	Remark
Power Supply voltage	DVDD	-0.3		4.5	Volt	
	AVDD	-0.3	-	14.5	Volt	
	VGH	-0.3		$V_{GL}+35.0$	Volt	
	VGL	-15		0.3	Volt	
Operating Temperature	Topr	-30	-	+85	°C	
Storage Temperature	Tstg	-40	-	+95	°C	

6-2 Operating Conditions

Item	Symbol	Condition	Min.	Typ.	Max.	Unit
Power Supply voltage	VDD	-	3.0	3.3	3.6	Volt
	AVDD	-		12.4		Volt
	VCOM	-		5.5		Volt
	VGH			19		Volt
	VGL	-		-10		Volt
Level Input Voltage (Digital signal)	VIH	-	$0.7*VDD$	-	VDD	Volt
	VIL	-	GND	-	$0.3*VDD$	Volt
Power Supply Current for LCM	VDD_IDD	VDD=3.3V	-	TBD	-	mA

6-3 Data Input Timing

6-3-1 TFT Data Input Timing

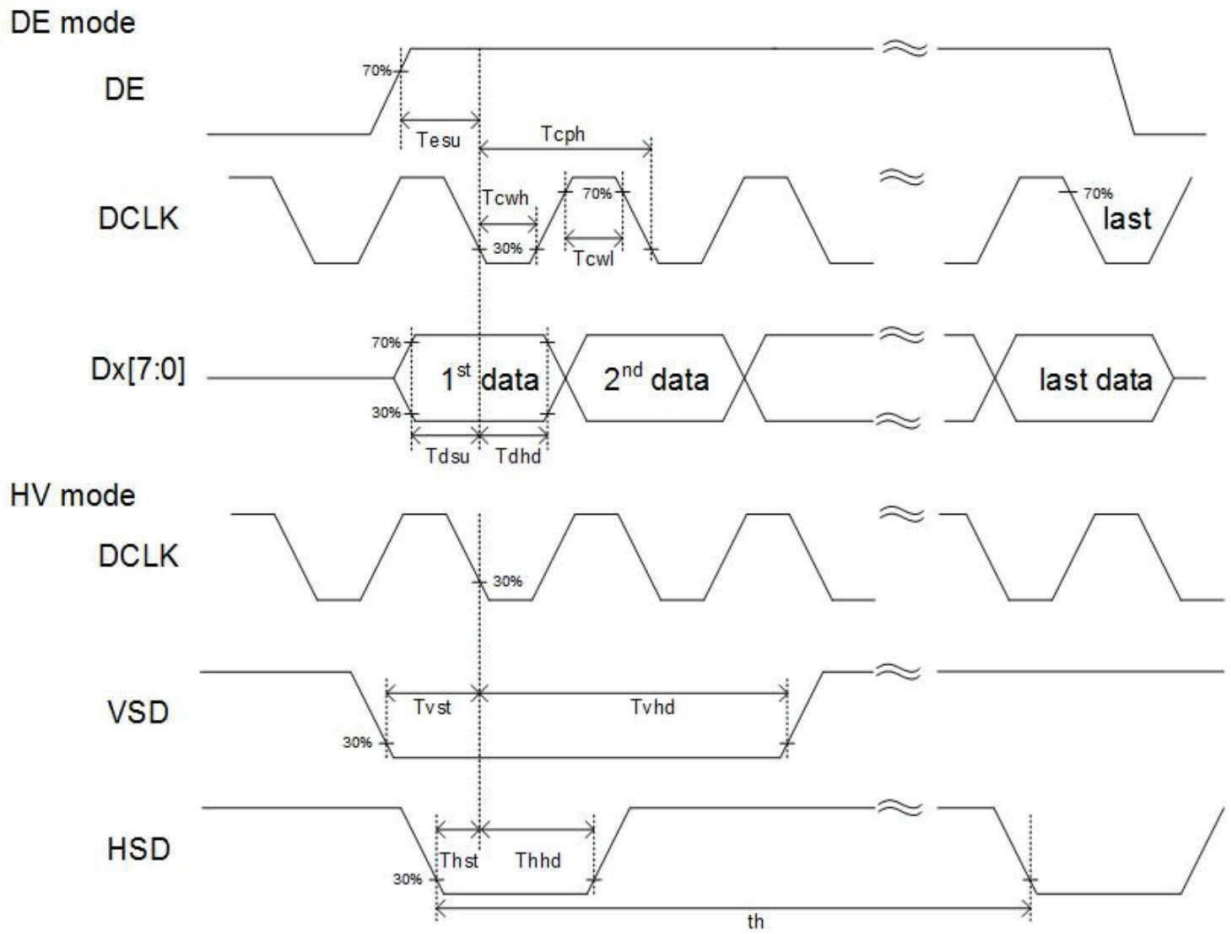

Input clock and data timing diagram.

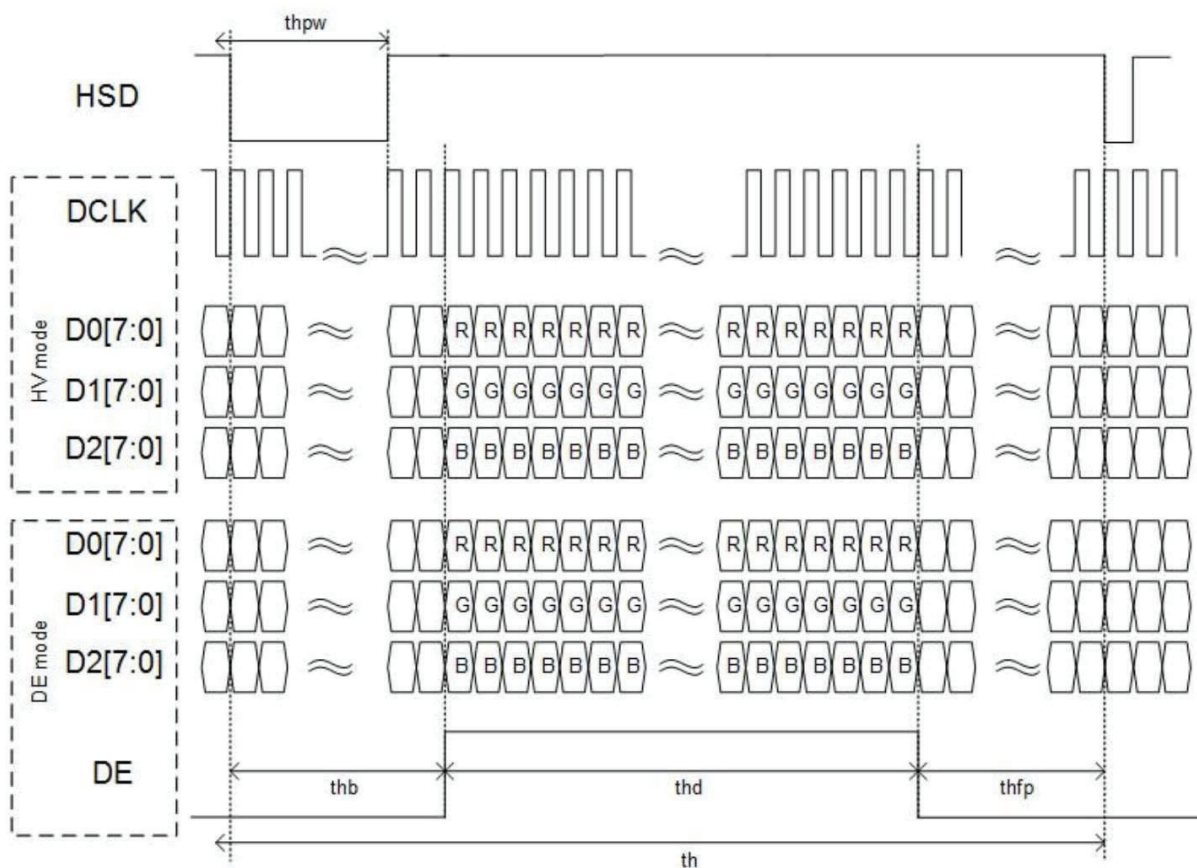
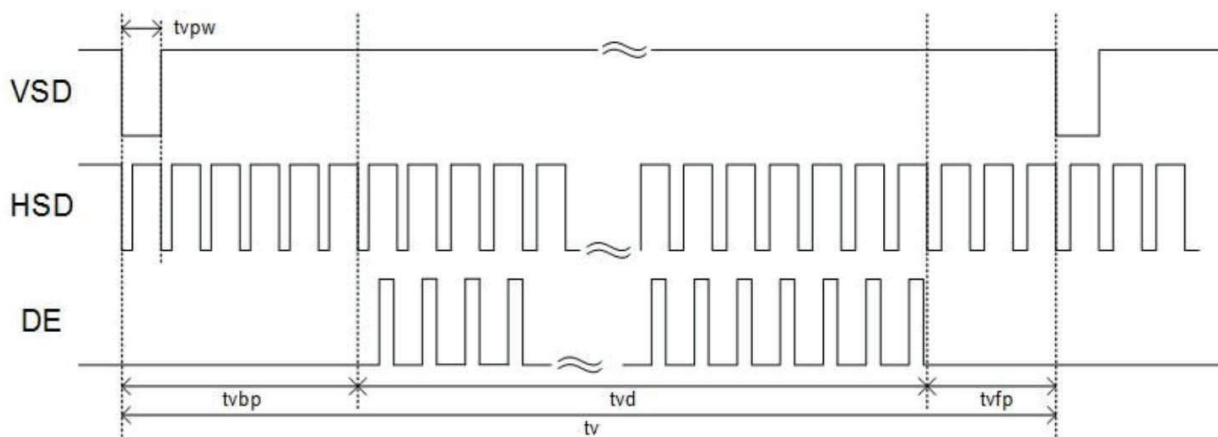

Data Input Format

AC Electrical Characteristics

Item	Symbol	Min.	Typ.	Max.	Unit	Note
DCLK cycle time	Tcph	20		220	ns	
DCLK pulse duty	Tcwh	35	50	65	%	
VSD setup time	Tvst	8			ns	
VSD hold time	Tvhd	8			ns	
HSD setup time	Thst	8			ns	
HSD hold time	Thhd	8			ns	
Data setup time	Tdsu	8			ns	
Data hold time	Tdhd	8			ns	
DE setup time	Tesu	8			ns	
DE hold time	Tehd	8			ns	
DCLK frequency	fclk	28	30	32	MHz	
Horizontal display area	thd	800			Tcph	
HSD period time	th	889	902	915	Tcph	
HSD pulse width	thpw	5	10	15	Tcph	
HSD back porch	thb	32			Tcph	
HSD front porch	thfp	52	60	68	Tcph	
Vertical display area	tvd	480			th	
VSD period time	tv	546	555	564	th	
VSD pulse width	tvpw	6	10	14	Th	
VSD back porch	tvb	5			th	
VSD front porch	tvfp	55	60	65	th	

6-4 Power Sequence

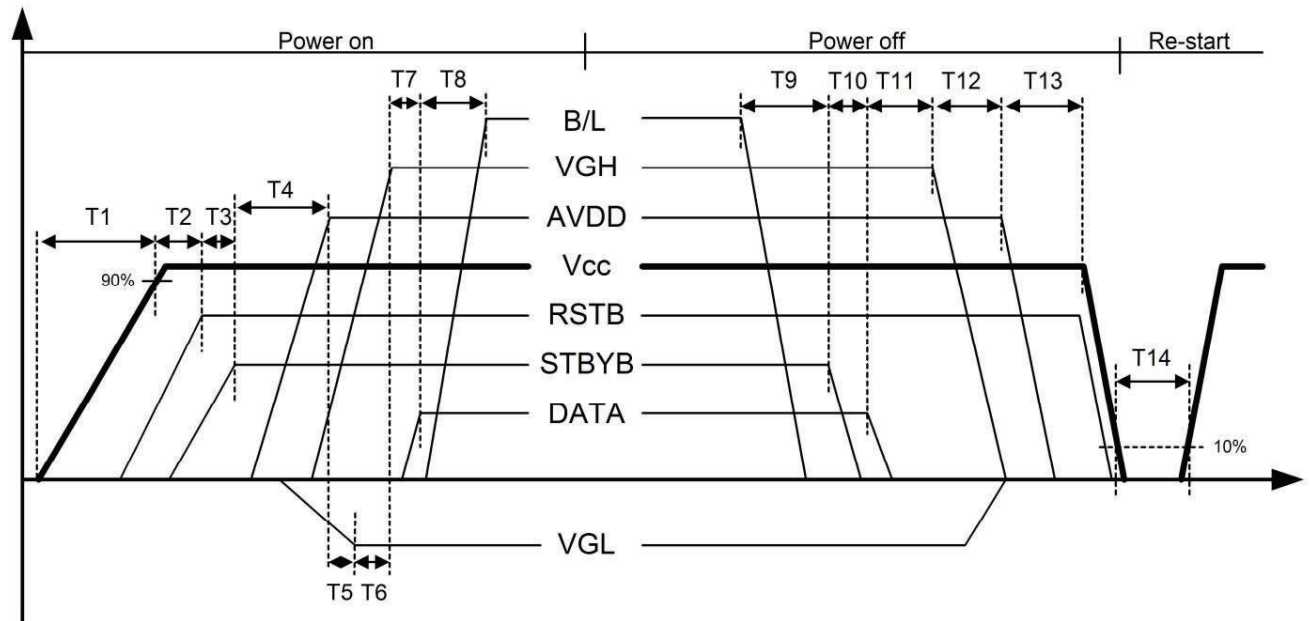

Item	Min	Typ.	Max.	Unit
T1	--	--	20	ms
T2	1	--	--	ms
T3	1	--	--	ms
T4	50	--	--	ms
T5	32	--	--	ms
T6	16	--	--	ms
T7	16	--	--	ms
T8	32	--	--	ms
T9	32	--	--	ms
T10	32	--	--	ms
T11	50	--	--	ms
T12	16	--	--	ms
T13	32	--	--	ms
T14	1000	--	--	ms

The Data are included in the R0~R7, G0~G7, B0~B7, HSD, VSD, DCLK, DE, MODE, SHLR, and UPDN.

7. Optical Characteristics:

Item	Symbol	Conditions	Specifications			Unit	Note	
			Min	Typ	Max			
Transmittance (With PLZ)	T (%)	-	-	3.8	-	-	-	
Contrast Ratio	CR	$\Theta=0$ Normal Viewing angle	700	1000	-		(1) (2)	
Response time	TR+TF	-	-	30	40	ms	(1) (3)	
Viewing angle	Hor.	Θ_{x+}	CR ≥ 10	-	85	-	deg.	-
		Θ_{x-}		-	85	-		
	Ver.	Θ_{y+}		-	85	-		
		Θ_{y-}		-	85	-		

Measuring Condition

1. Measuring surrounding: dark room
2. Ambient temperature: $25 \pm 2^\circ\text{C}$
3. 30 min. Warm-up time.

Color of CIE Coordinate:

Item		Symbol	Condition	Min.	Typ.	Max.
Chromaticity Coordinates (Transmissive)	Red	x	$\theta = \phi = 0^\circ$ LED Backlight	TBD	0.655	TBD
		y		TBD	0.318	TBD
	Green	x		TBD	0.261	TBD
		y		TBD	0.576	TBD
	Blue	x		TBD	0.140	TBD
		y		TBD	0.082	TBD
	White	x		TBD	0.305	TBD
		y		TBD	0.324	TBD

Note (1) Definition of Viewing Angle:

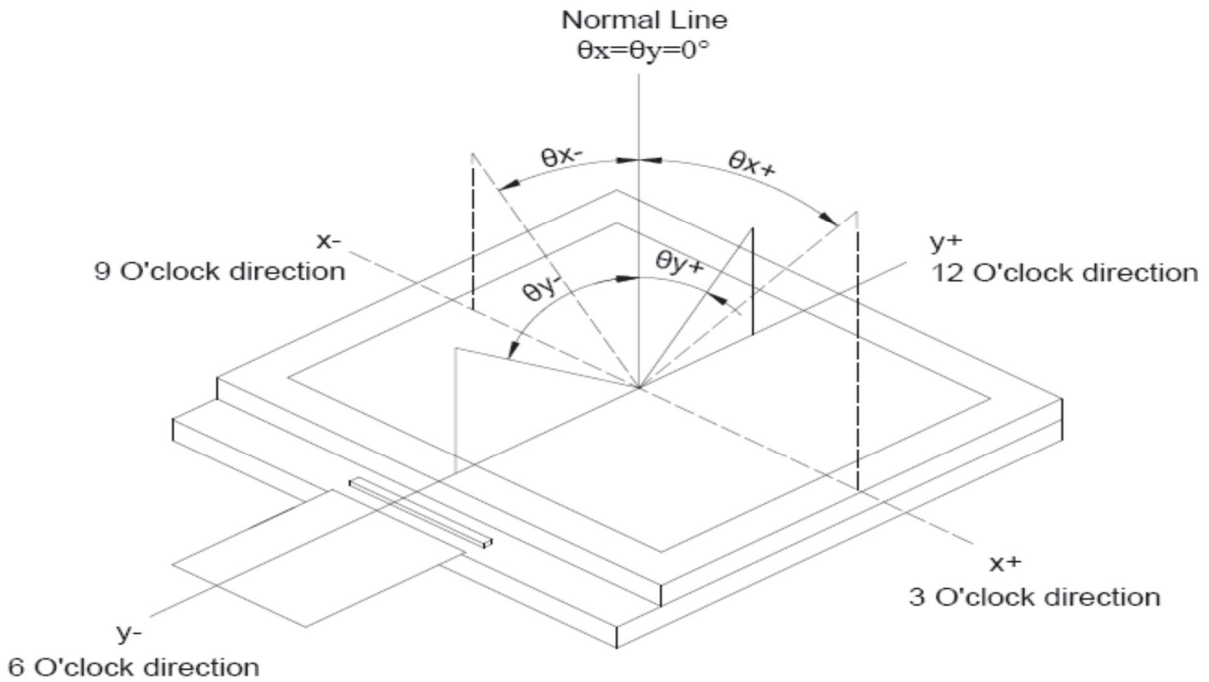

Note (2) Definition of Contrast Ratio (CR):
measured at the center point of panel

$$\text{Contrast ratio (CR)} = \frac{\text{Photo detector output when LCD is at "White" state}}{\text{Photo detector output when LCD is at "Black" state}}$$

Note (3) Definition of Response Time: Sum of TR and TF

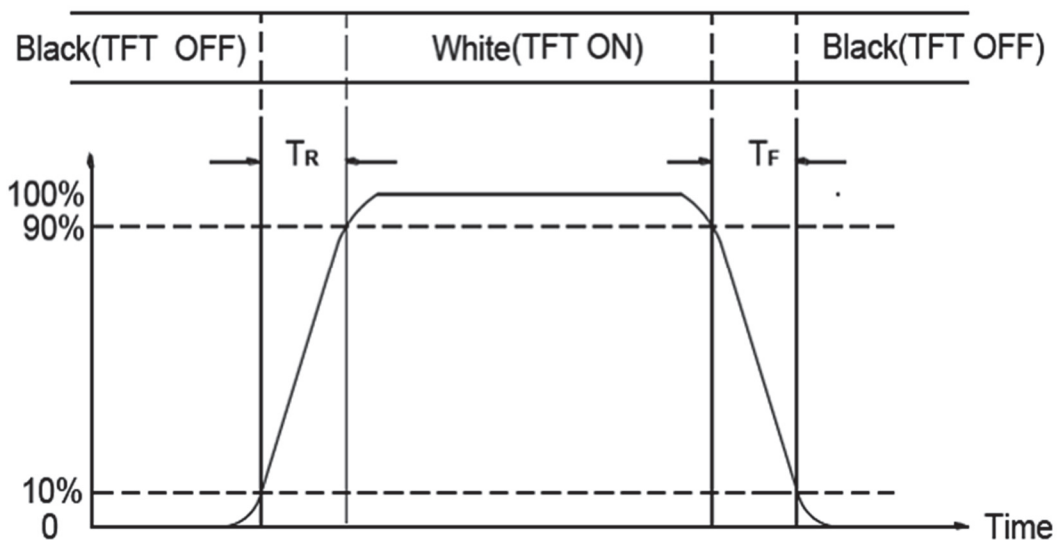

8. Interface Pin Assignment:

No.	Symbol	Function
1~2	LED+	Power for LED backlight (Anode)
3~4	LED-	Power for LED backlight (Cathode)
5	GND	Power ground
6	VCOM	Common voltage input.
7	DVDD	Power supply.
8	MODE	DE/SYNC mode select. Normally pull high H:DE mode. L:HSD/VSD mode
9	DE	Data Enable signal
10	VSYNC	Vertical sync input. Negative polarity
11	HSYNC	Horizontal sync input. Negative polarity
12~19	B7~B0	Blue Data Input
20~27	G7~G0	Green Data Input
28~35	R7~R0	Red Data Input
36	GND	Power ground
37	DCLK	Data clock Input
38	GND	Power ground
39	LCD_LR	Left or Right Display Control
40	LCD_UD	Up / Down Display Control
41	VGH	Positive Power for TFT.
42	VGL	Negative Power for TFT.
43	AVDD	Analog Power input.
44	RST_LCD_N	Global reset pin. Active Low to enter Reset State. (Normally pull high.) Suggest to connecting with an RC reset circuit for stability.
45	NC	No connection
46	VCOM	Common voltage input.
47	LCD_DITHB	Dithering function enable control. (Normally pull high) DITHB = "1", Disable internal dithering function DITHB = "0", Enable internal dithering function
48	GND	Power ground
49	NC	No connection
50	NC	No connection

9. Block Diagram:

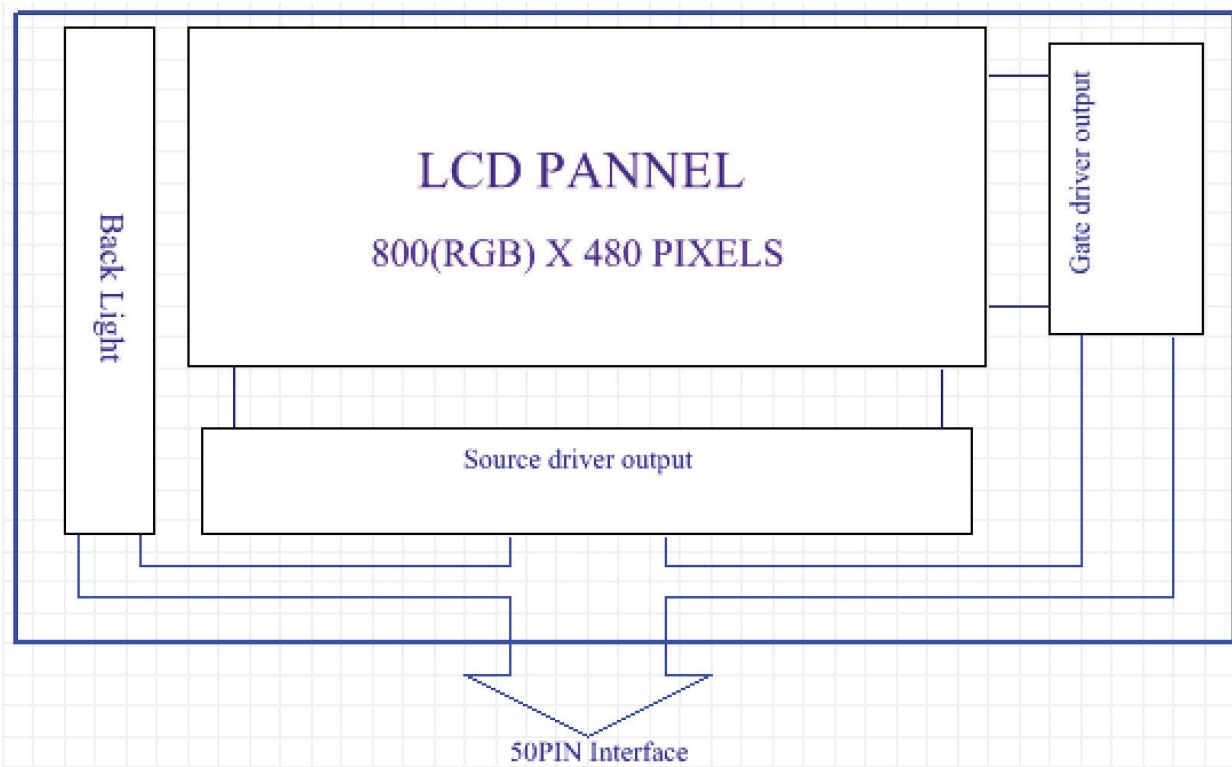

10. Backlight:

1. Standard Lamp Styles (Edge Lighting Type):
The LED chips are distributed over the edge light area of the illumination unit, which gives the less power consumption:
2. The Main Advantages of the LED Backlight are as following:
 - 2.1 The brightness of the backlight can simply be adjusted.
By a resistor or a potentiometer.

3. Data About LED Backlight:

($T_a=25^{\circ}\text{C}$)

PARAMETER	Sym.	Min.	Typ.	Max.	Unit	Test Condition	Note
Supply Current	I	-	270	-	mA	-	
Supply Voltage	V	18.9	21.7	24.5	V	If=270mA	
Luminous Intensity for LCM	IV	800	1000	-	cd/m ²		2
Uniformity for LCM	-	75	-	-	%		3
Life Time	-	50000	-	-	Hr.		4
Color	White						

NOTE:

1. Backlight Only
2. Average Luminous Intensity of P1-P9
3. Uniformity = Min/Max * 100%
4. LED life time defined as follows: The final brightness is at 50% of original brightness

Measured Method: (X*Y: Light Area)

Internal Circuit Diagram

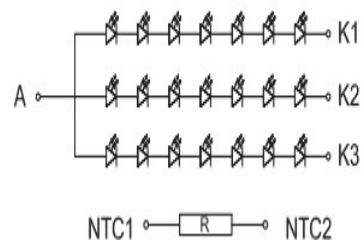
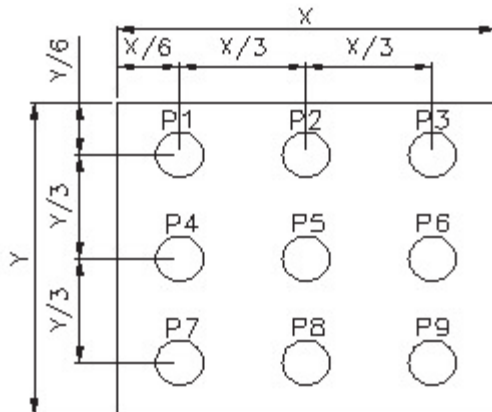

(Effective spatial Distribution)

Using aperture of 1°, distance 50cm.

11. Standard Specification for Reliability :

11-1. Standard Specifications for Reliability of LCD Module

No	Item	Description
01	High temperature operation	The sample should be allowed to stand at 85°C for 120 hours under driving condition and then returning it to normal temperature condition, and allowing it stand for 2 hours.
02	Low temperature operation	The sample should be allowed to stand at -30°C for 120 hours under driving condition and then returning it to normal temperature condition, and allowing it stand for 2 hours.
03	High temperature storage	The sample should be allowed to stand at 95°C for 240 hours under no-load condition, and then returning it to normal temperature condition, and allowing it stand for 2 hours.
04	Low temperature storage	The sample should be allowed to stand at -40°C for 240 hours under no-load condition, then returning it to normal temperature condition, and allowing it stand for 2 hours.
05	Moisture storage	The sample should be allowed to stand at 60°C,90%RH MAX for 240 hours under no-load condition, then taking it out and drying it at normal temperature for 2 hours.
06	Thermal shock storage	The sample should be allowed to stand the following 10 cycles : -40°C for 30 minutes → normal temperature for 5 minutes → +85°C for 30 minutes → normal temperature for 5 minutes, as one cycle.
07	Packing vibration	Frequency range : 10Hz ~ 55Hz Amplitude of vibration : 1.5mm Sweep time: 12 min X,Y,Z 2 hours for each direction.
08	Packing drop test	According to ISTA 1A 2001.
09	Electrical Static Discharge	Air: ±4KV 150pF/330Ω 5 times
		Contact: ±2KV 150pF/330Ω 5 time
10	Imaging sticking	Burn in:5*5 Chess,1h@25°C. Inspection Pattern:50% grey, Perpendicular view, after 5 Min,the mura must disappear 

*Sample size for each test item is 3~5pcs

11 - 2. Testing Conditions and Inspection Criteria

For the final test the testing sample must be stored at room temperature for 24 hours, after the tests listed in Table 12.1, Standard specifications for Reliability have been executed in order to ensure stability.

No	Item	Test Model	In section Criteria
01	Current Consumption	Refer To Specification	The current consumption should conform to the product specification.
02	Contrast	Refer To Specification	After the tests have been executed, the contrast must be larger than half of its initial value prior to the tests.
03	Appearance	Visual inspection	Defect free.

11- 3. MTBF

MTBF	Functions, performance, appearance, etc. shall be free from remarkable deterioration within 50,000 hours under ordinary operating and storage conditions room temperature (25±5°C), normal humidity (50±10% RH), and in area not exposed to direct sun light.
------	---

12. Specification of Quality Assurance:

12-1. Purpose

This standard for Quality Assurance should affirm the quality of LCD module products to supply to purchaser by YEEBO CORPORATION (Supplier).

12-2. Standard for Quality Test

a. Inspection:

Before delivering, the supplier should take the following tests, and affirm the quality of product.

b. Electro-Optical Characteristics:

According to the individual specification to test the product.

c. Test of Appearance Characteristics:

According to the individual specification to test the product.

d. Test of Reliability Characteristics:

According to the definition of reliability on the specification for testing products.

e. Delivery Test:

Before delivering, the supplier should take the delivery test.

(i) Test method: According to **ISO2859-1**.General Inspection Level **II** take a single time.

(ii) The defects classify of AQL as following:

Major defect: AQL = 0.65

Minor defect: AQL = 2.5

Total defects: AQL = 2.5

12-3. Non- conforming Analysis & Deal With Manners

a. Non- conforming Analysis:

(i) Purchaser should supply the detail data of non- conforming sample and the non-conforming.

(ii) After accepting the detail data from purchaser, the analysis of non- conforming should be finished in two weeks.

(iii) If supplier can not finish analysis on time, must announce purchaser before 3 days.

b. Disposition of non- conforming:

(i) If find any product defect of supplier during assembly time, supplier must change the good product for every defect after recognition.

(ii) Both supplier and customer should analyze the reason and discuss the disposition of non- conforming when the reason of nonconforming is not sure.

12-4. Agreement items

Both sides should discuss together when the following problems happen.

a. There is any problem of standard of quality assurance, and both sides should think that must be modified.

b. There is any argument item which does not record in the standard of quality assurance.

c. Any other special problem.

12-5. Standard of The Product Appearance Test

a. Manner of appearance test:

(i) The test must be under 20W × 2 or 40W fluorescent light, and the distance of view must be at 30±5cm.

(ii) When test the model of transmissive product must add the reflective plate.

(iii) The test direction is base on around 10° of vertical line.

(iiii) Temperature: 25±5°C Humidity: 60±10%RH

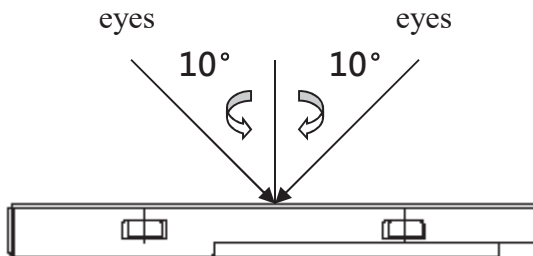

(iv) Definition of area:

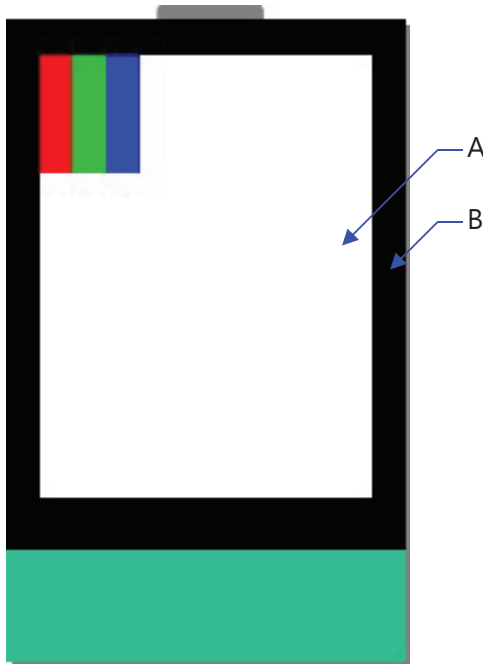

A. Area: Viewing area.

B. Area: Out of viewing area.
(Outside viewing area)

b. Basic principle:

(i) It will accord to the AQL when the standard can not be described.

(ii) The sample of the lowest acceptable quality level must be discussed by both supplier and customer when any dispute happened.

(iii) Must add new item on time when it is necessary.

c. Standard of inspection: (Unit: mm)

12-6. Inspection specification
Defect out of viewing area can be neglected.

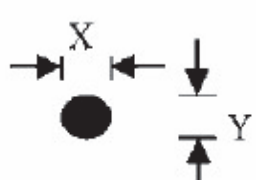
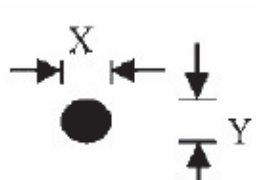
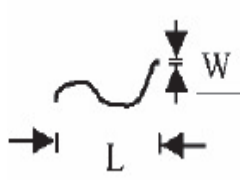
NO	Item	Criterion	AQL																							
01	Electrical Testing	1.1 Missing vertical, horizontal segment, segment contrast defect. 1.2 Missing character, dot or icon. 1.3 Display malfunction. 1.4 No function or no display. 1.5 Current consumption exceeds product specifications. 1.6 LCD viewing angle defect. 1.7 Mixed product types. 1.8 Flicker	0.65																							
02	Black or White spots or Bright spots or Color spots on LCD (Display only)	2.1 Dot dimension as below drawing: $\Phi = (X+Y) / 2$  <table border="1" data-bbox="810 779 1347 969"> <thead> <tr> <th>Size(mm)</th> <th>Acceptable Q'ty</th> </tr> </thead> <tbody> <tr> <td>$\Phi \leq 0.20$</td> <td>Accept no dense</td> </tr> <tr> <td>$0.20 < \Phi \leq 0.40$</td> <td>5</td> </tr> <tr> <td>$0.40 < \Phi$</td> <td>0</td> </tr> </tbody> </table> 2.2 Not visible through 5% ND filter * Densely spaced: No more than two spots within 3mm.	Size(mm)	Acceptable Q'ty	$\Phi \leq 0.20$	Accept no dense	$0.20 < \Phi \leq 0.40$	5	$0.40 < \Phi$	0	2.5															
Size(mm)	Acceptable Q'ty																									
$\Phi \leq 0.20$	Accept no dense																									
$0.20 < \Phi \leq 0.40$	5																									
$0.40 < \Phi$	0																									
03	LCD and Touch Panel black spots, white spots, contamination (non – display)	3.1 Round type: As following drawing $\Phi = (X+Y) / 2$  <table border="1" data-bbox="810 1205 1347 1395"> <thead> <tr> <th>Size(mm)</th> <th>Acceptable Q'ty</th> </tr> </thead> <tbody> <tr> <td>$\Phi \leq 0.20$</td> <td>Accept no dense</td> </tr> <tr> <td>$0.20 < \Phi \leq 0.40$</td> <td>5</td> </tr> <tr> <td>$0.40 < \Phi$</td> <td>0</td> </tr> </tbody> </table> * Densely spaced: No more than two spots within 3mm. 3.2 Line type: (As following drawing)  <table border="1" data-bbox="715 1570 1347 1933"> <thead> <tr> <th>Length(mm)</th> <th>Width(mm)</th> <th>Acceptable Q'ty</th> </tr> </thead> <tbody> <tr> <td>$L \leq 10$</td> <td>$W \leq 0.1$</td> <td>Accept no dense</td> </tr> <tr> <td>$L \leq 10.0$</td> <td>$0.1 < W \leq 0.25$</td> <td>4</td> </tr> <tr> <td>$L > 10$</td> <td>----</td> <td>Rejection</td> </tr> <tr> <td>----</td> <td>$0.25 < W$</td> <td>Rejection</td> </tr> </tbody> </table> * Densely spaced: No more than two lines within 3mm.	Size(mm)	Acceptable Q'ty	$\Phi \leq 0.20$	Accept no dense	$0.20 < \Phi \leq 0.40$	5	$0.40 < \Phi$	0	Length(mm)	Width(mm)	Acceptable Q'ty	$L \leq 10$	$W \leq 0.1$	Accept no dense	$L \leq 10.0$	$0.1 < W \leq 0.25$	4	$L > 10$	----	Rejection	----	$0.25 < W$	Rejection	2.5
Size(mm)	Acceptable Q'ty																									
$\Phi \leq 0.20$	Accept no dense																									
$0.20 < \Phi \leq 0.40$	5																									
$0.40 < \Phi$	0																									
Length(mm)	Width(mm)	Acceptable Q'ty																								
$L \leq 10$	$W \leq 0.1$	Accept no dense																								
$L \leq 10.0$	$0.1 < W \leq 0.25$	4																								
$L > 10$	----	Rejection																								
----	$0.25 < W$	Rejection																								

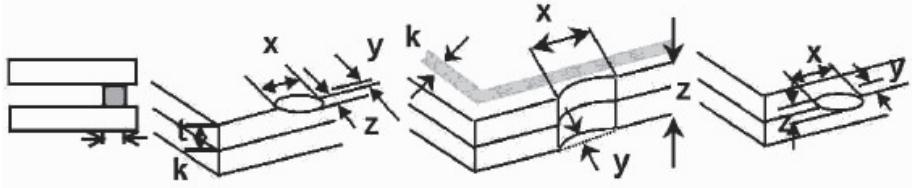
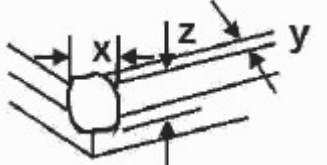
NO	Item	Criterion	AQL																		
04	Polarizer bubbles	If bubbles are visible, judge using black spot specifications, not easy to find, must check in specify direction <table border="1" data-bbox="847 367 1347 651"> <thead> <tr> <th>Size Φ(mm)</th> <th>Acceptable Q'ty</th> </tr> </thead> <tbody> <tr> <td>$\Phi \leq 0.20$</td> <td>Accept no dense</td> </tr> <tr> <td>$0.20 < \Phi \leq 0.50$</td> <td>4</td> </tr> <tr> <td>$0.50 < \Phi \leq 1.00$</td> <td>3</td> </tr> <tr> <td>$1.00 < \Phi$</td> <td>0</td> </tr> <tr> <td>Total Q'ty</td> <td>4</td> </tr> </tbody> </table>	Size Φ (mm)	Acceptable Q'ty	$\Phi \leq 0.20$	Accept no dense	$0.20 < \Phi \leq 0.50$	4	$0.50 < \Phi \leq 1.00$	3	$1.00 < \Phi$	0	Total Q'ty	4	2.5						
Size Φ (mm)	Acceptable Q'ty																				
$\Phi \leq 0.20$	Accept no dense																				
$0.20 < \Phi \leq 0.50$	4																				
$0.50 < \Phi \leq 1.00$	3																				
$1.00 < \Phi$	0																				
Total Q'ty	4																				
05	Scratches	Follow NO.3 -2 Line Type.																			
06	Mura	Not visible through 5% ND filter.	2.5																		
07	Chipped glass	Symbols: x: Chip length y: Chip width z: Chip thickness k: Seal width t: Glass thickness a: LCD side length L: Electrode pad length 7.1 General glass chip: 7.1.1 Chip on panel surface and crack between panels:  <table border="1" data-bbox="395 1173 1216 1346"> <thead> <tr> <th>z: Chip thickness</th> <th>y: Chip width</th> <th>x: Chip length</th> </tr> </thead> <tbody> <tr> <td>$Z \leq 1/2t$</td> <td>Not over viewing area</td> <td>$x \leq 1/8a$</td> </tr> <tr> <td>$1/2t < z \leq 2t$</td> <td>Not exceed 1/3k</td> <td>$x \leq 1/8a$</td> </tr> </tbody> </table> Unit: mm ☉ If there are 2 or more chips, x is the total length of each chip 7.1.2 Corner crack:  <table border="1" data-bbox="395 1760 1216 1933"> <thead> <tr> <th>z: Chip thickness</th> <th>y: Chip width</th> <th>x: Chip length</th> </tr> </thead> <tbody> <tr> <td>$Z \leq 1/2t$</td> <td>Not over viewing area</td> <td>$x \leq 1/8a$</td> </tr> <tr> <td>$1/2t < z \leq 2t$</td> <td>Not exceed 1/3k</td> <td>$x \leq 1/8a$</td> </tr> </tbody> </table> Unit: mm	z: Chip thickness	y: Chip width	x: Chip length	$Z \leq 1/2t$	Not over viewing area	$x \leq 1/8a$	$1/2t < z \leq 2t$	Not exceed 1/3k	$x \leq 1/8a$	z: Chip thickness	y: Chip width	x: Chip length	$Z \leq 1/2t$	Not over viewing area	$x \leq 1/8a$	$1/2t < z \leq 2t$	Not exceed 1/3k	$x \leq 1/8a$	2.5
z: Chip thickness	y: Chip width	x: Chip length																			
$Z \leq 1/2t$	Not over viewing area	$x \leq 1/8a$																			
$1/2t < z \leq 2t$	Not exceed 1/3k	$x \leq 1/8a$																			
z: Chip thickness	y: Chip width	x: Chip length																			
$Z \leq 1/2t$	Not over viewing area	$x \leq 1/8a$																			
$1/2t < z \leq 2t$	Not exceed 1/3k	$x \leq 1/8a$																			

		⊙ If there are 2 or more chips, x is the total length of each chip	
--	--	--	--

NO	Item	Criterion	AQL
----	------	-----------	-----

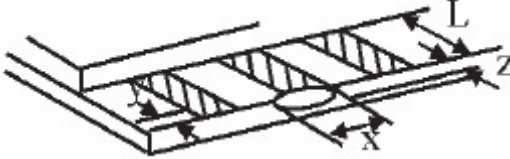
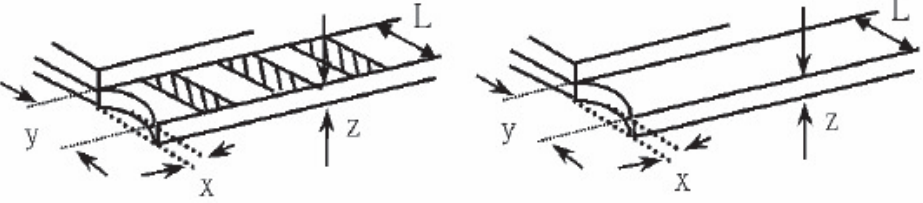
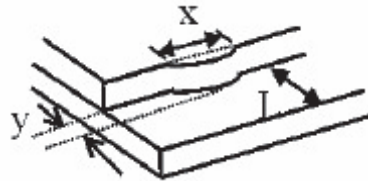
08	Glass crack	<p>Symbols: x: Chip length y: Chip width z: Chip thickness k: Seal width t: Glass thickness a: LCD side length L: Electrode pad length</p> <p>8.1 Protrusion over terminal: 8.1.1 Chip on electrode pad:</p>  <table border="1" data-bbox="539 611 1225 768"> <tr> <td>y: Chip width</td> <td>x: Chip length</td> <td>z: Chip thickness</td> </tr> <tr> <td>$y \leq 0.5\text{mm}$</td> <td>$x \leq 1/8a$</td> <td>$0 < z \leq t$</td> </tr> </table> <p>8.1.2 Non-conductive portion:</p>  <table border="1" data-bbox="539 1126 1225 1283"> <tr> <td>y: Chip width</td> <td>x: Chip length</td> <td>z: Chip thickness</td> </tr> <tr> <td>$y \leq L$</td> <td>$x \leq 1/8a$</td> <td>$0 < z \leq t$</td> </tr> </table> <p>⊙ If there chipped area touches the ITO terminal, over 2/3 of the ITO must remain and be inspected according to electrode terminal specifications.</p> <p>⊙ If the product will be heat sealed by the customer, the alignment mark must not be damaged.</p> <p>8.1.3 Substrate protuberance and internal crack</p>  <table border="1" data-bbox="858 1630 1297 1787"> <tr> <td>y: width</td> <td>x: length</td> </tr> <tr> <td>$y \leq 1/3L$</td> <td>$X \leq a$</td> </tr> </table>	y: Chip width	x: Chip length	z: Chip thickness	$y \leq 0.5\text{mm}$	$x \leq 1/8a$	$0 < z \leq t$	y: Chip width	x: Chip length	z: Chip thickness	$y \leq L$	$x \leq 1/8a$	$0 < z \leq t$	y: width	x: length	$y \leq 1/3L$	$X \leq a$	2.5
		y: Chip width	x: Chip length	z: Chip thickness															
$y \leq 0.5\text{mm}$	$x \leq 1/8a$	$0 < z \leq t$																	
y: Chip width	x: Chip length	z: Chip thickness																	
$y \leq L$	$x \leq 1/8a$	$0 < z \leq t$																	
y: width	x: length																		
$y \leq 1/3L$	$X \leq a$																		

NO	Item	Criterion	AQL
09	Cracked glass	The LCD with extensive crack is not acceptable.	2.5
10	Backlight elements	10.1 Illumination source flickers when lit. 10.2 Spots or scratches that appear when lit must be judged. Using LCD spot, lines and contamination standards. 10.3 Backlight doesn't light or color is wrong.	2.5 2.5 0.65
11	Bezel	Bezel must comply with product specifications.	2.5
12	PCB、COB	12.1 COB seal may not have pinholes larger than 0.2mm or contamination. 12.2 COB seal surface may not have pinholes through to the IC. 12.3 The height of the COB should not exceed the height indicated in the assembly diagram. 12.4 There may not be more than 2mm of sealant outside the seal area on PCB. And there should be no more than three places. 12.5 Parts on PCB must be the same as on the production characteristic chart, There should be no wrong parts, missing parts or excess parts. 12.6 The jumper on the PCB should conform to the product characteristic chart. 12.7 PCBA cosmetic control base on latest IPC standard,IPC-A-610,acceptalbe limit of grade 2.	2.5 2.5 2.5 2.5 0.65 0.65 2.5
13	FPC	13.1 FPC terminal damage \leq 1/2 FPC terminal width and can not affect the function , we judge accept. 13.2 FPC alignment hole damage \leq 1/2 alignment area and can not affect the function , we judge accept.	2.5 2.5
14	Soldering	14.1 No cold solder joints, missing solder connections, oxidation or icicle. 14.2 No short circuits in components on PCB or FPC.	2.5 0.65

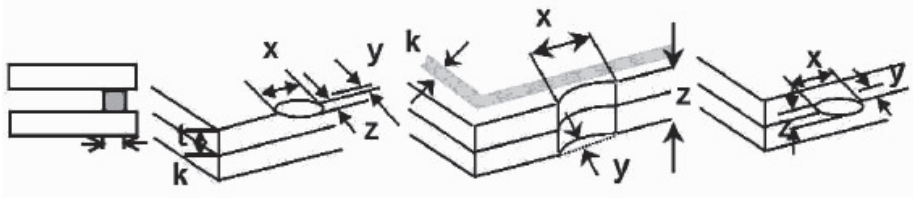
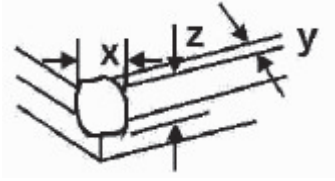
NO	Item	Criterion	AQL												
15	Touch Panel Chipped glass	<p>Symbols: x: Chip length y: Chip width z: Chip thickness k: Seal width t: Touch Panel Total thickness a: LCD side length L: Electrode pad length</p> <p>15.1 General glass chip: 15.1.1 Chip on panel surface and crack between panels:</p>  <table border="1" data-bbox="395 770 1216 985"> <tr> <td>z: Chip thickness</td> <td>y: Chip width</td> <td>x: Chip length</td> </tr> <tr> <td>$Z \leq t$</td> <td>$\leq 1/2 k$ and not over viewing area</td> <td>$x \leq 1/8a$</td> </tr> </table> <p>⊙ Unit: mm ⊙ If there are 2 or more chips, x is the total length of each chip</p> <p>15.1.2 Corner crack:</p>  <table border="1" data-bbox="395 1393 1216 1608"> <tr> <td>z: Chip thickness</td> <td>y: Chip width</td> <td>x: Chip length</td> </tr> <tr> <td>$z \leq t$</td> <td>$\leq 1/2 k$ and not over viewing area</td> <td>$x \leq 1/8a$</td> </tr> </table> <p>⊙ Unit: mm ⊙ If there are 2 or more chips, x is the total length of each chip</p>	z: Chip thickness	y: Chip width	x: Chip length	$Z \leq t$	$\leq 1/2 k$ and not over viewing area	$x \leq 1/8a$	z: Chip thickness	y: Chip width	x: Chip length	$z \leq t$	$\leq 1/2 k$ and not over viewing area	$x \leq 1/8a$	2.5
z: Chip thickness	y: Chip width	x: Chip length													
$Z \leq t$	$\leq 1/2 k$ and not over viewing area	$x \leq 1/8a$													
z: Chip thickness	y: Chip width	x: Chip length													
$z \leq t$	$\leq 1/2 k$ and not over viewing area	$x \leq 1/8a$													

NO	Item	Criterion		AQL	
16	Touch Panel(Fish eye)	SIZE(mm)	Acceptable Q'ty		2.5
		$L \leq 0.7$	Accept no dense		
		$L > 0.7\text{mm}$	0		
17	Touch Panel Newton ring	Newton ring dimension $\leq 1/2$ touch panel area and not affect font and line distortion($\leq 2.5\%$) , it is acceptable.		2.5	
18	Touch Panel Linearity	Less than 2.5% is acceptable.		2.5	
19	LCD Ripple	Touch the touch panel , can not see the LCD ripple. Pen: R 1.0mm silicon rubber. Operation Force: 80g		2.5	
20	General appearance	20.1 Pin type must match type in specification sheet.		0.65	
		20.2 LCD pin loose or missing pins.		0.65	
		20.3 Product packaging must the same as specified on packaging specification sheet.		0.65	
		20.4 Product dimension and structure must conform to product specification sheet.		0.65	

13. Handling Precaution:

13-1 Handling of LCM

- Don't give external shock.
- Don't apply excessive force on the surface.
- Liquid in LCD is hazardous substance. Must not lick and swallow. when the liquid is attach to your hand, skin, cloth etc. Wash it out thoroughly and immediately.
- Don't operate it above the absolute maximum rating.
- Don't disassemble the LCM.
- The operators should be grounded whenever he/she comes into contact with the module. Never touch any of the conductive parts such as the LSI pads, the copper leads on the PCB and the interface terminals with any parts of the human body.
- The modules should be kept in antistatic bags or other containers resistant to static for storage.
- The module is coated with a film to protect the display surface. Be care when peeling off this protective film since static electricity may be generated.

13-2 Storage

- Store in an ambient temperature of $25\pm 10^{\circ}\text{C}$, and in a relative humidity of $50\pm 10\%\text{RH}$. Don't expose to sunlight or fluorescent light.
- Storage in a clean environment, free from dust, active gas, and solvent.
- Store in anti-static electricity container.
- Store without any physical load.

13-3 Soldering

- Use only soldering irons with proper grounding and no leakage.
- Iron: No higher than $310\pm 10^{\circ}\text{C}$ and less than 3 sec during Hand soldering.
- Rewiring: no more than 2 times.

14. Warranty

This product has been manufactured to specifications as a part for use in your company's general electronic products. It is guaranteed to perform according to delivery specifications. For any other

use apart from general electronic equipment, we will not take responsibility if the product is used in

medical devices, nuclear power control equipment, aerospace equipment, fire and security systems,

or any other applications in which there is a direct risk to human life and where extremely high levels of reliability are required. If the product is to be used in any of the above applications, we will need to enter into a separate product liability agreement.

1. We cannot accept responsibility for any defect arise after additional process of the product (including disassembly and reassembly), after product delivery.

2. We cannot accept responsibility for any defect, which may arise after the application of strong external force to the product.

3. We cannot accept responsibility for any defect, which may arise due to the application of static

electricity after the product has passed your company's acceptance inspection procedures.

4. We can not accept responsibility for industrial property, which may arise through the use of your product , with exception to those issues relating directly to the structure or method of manufacturing of our product within one year from YEEBO shipment.

5. For Heatseal Product which required to heatseal by customer side, parts must be used within three months after delivery from factory.

6. For TAB Product which required to solder by customer side, parts must be used within three months after delivery from factory.

7. The liability of YB is limited to repair or replacement on the terms set forth below. YB will not be responsible for any subsequent or consequential events or injury or damage to any personnel or

user including third party personnel and/or user. Unless otherwise agreed in writing between YB and the customer, YB will only replace or repair any of its LCD which is found defective electrically or visually when inspected in accordance with YB GENERAL LCD INSPECTION STANDARD.

15. Guarantee:

Our products meet requirements of the environment.

YEEBO ROHS requirement is based on European Union Directive 2011/65/EU (ROHS)

Requirements and Update.